



赣工机械设备科技(东莞)有限公司

TEL: 15920631511

PART NUMBER: STD267

REVISION: E

STD267

E

Product Specifications

Model Number	MAX. PRESS.		MAX. SPEED	HP	kW	Net Wt.	
	bar.	PSI				lbs.	kg
2AM-NRV-90	7.0	100	3,000 RPM	.95	0.70	4.2	1.9
* 2AM-NRV-90A	7.0	100	3,000 RPM	.95	0.70	4.2	1.9

SOUND LEVEL 76 dB(A) MAX.
 NORMAL AMBIENT +1°C. - 120°C.
 RELATIVE HUMIDITY 0% - 100%
 ENVIRONMENT HAZARDOUS AMBIENT COMBUSTIBLE
GAS & DUST +1°C TO +40°C

NOTES:

- 1) TECHNICAL DATA SUBJECT TO CHANGE W/O NOTICE.
- 2) ALL DIMENSIONS ARE REFERENCE ONLY UNLESS TOLERANCED.
- 3) * DENOTES INACTIVE.
- 4) CONFORMS TO EUROPEAN STANDARD EN13463-1 NON-ELECTRICAL EQUIPMENT FOR EXPLOSIVE ATMOSPHERES GROUP II CAT 2 (GAS & DUST), PROTECTED BY CONSTRUCTION (SURFACE TEMP RATED 135°C)

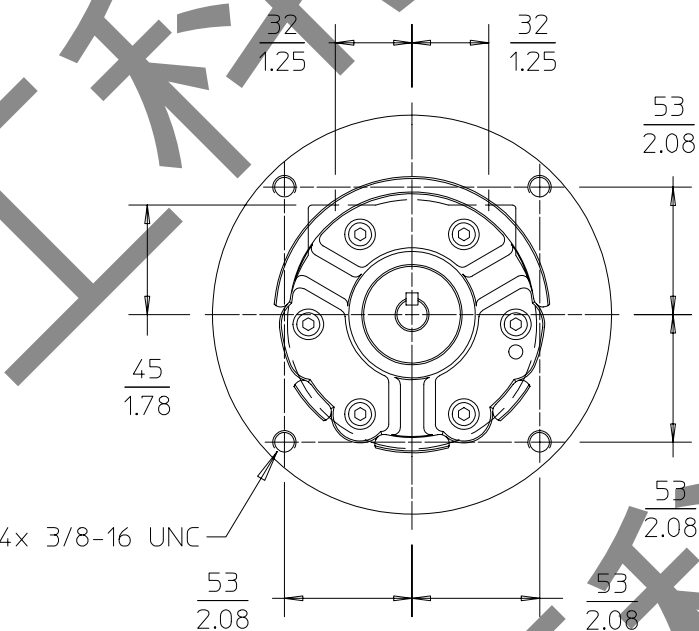
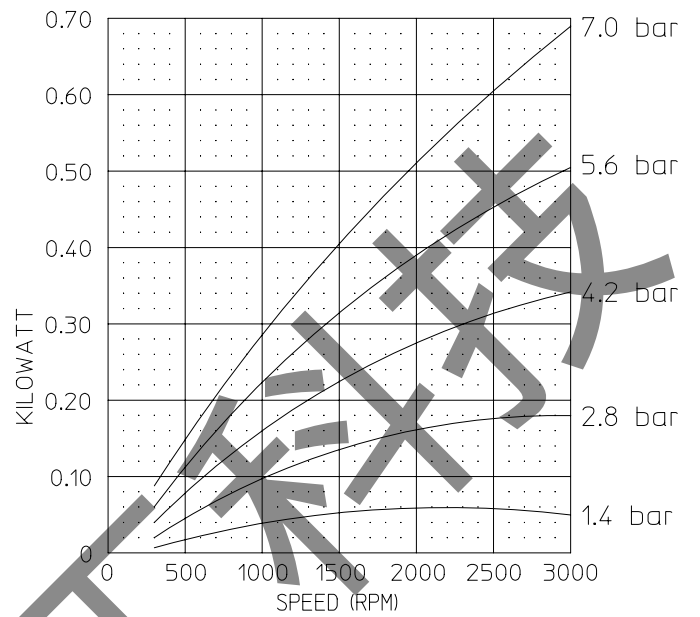
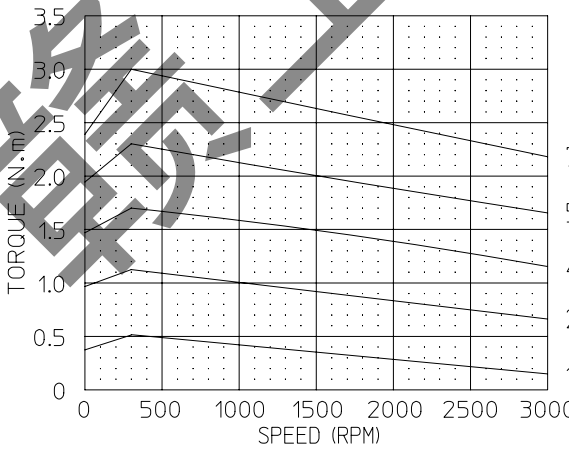
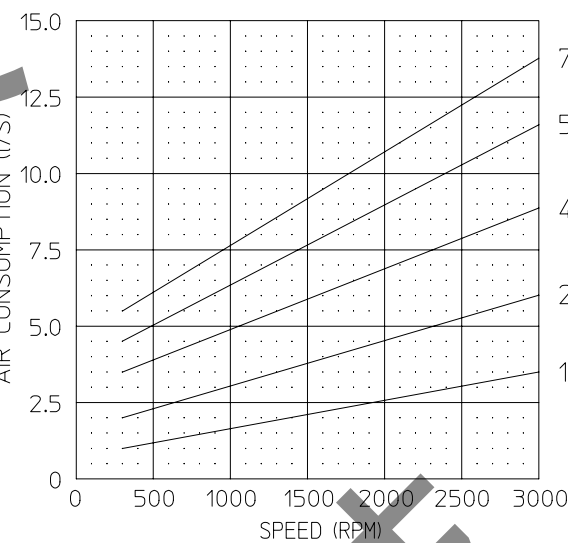
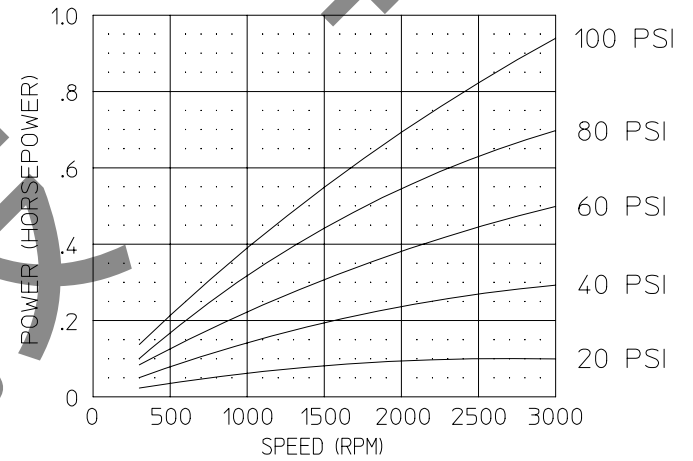
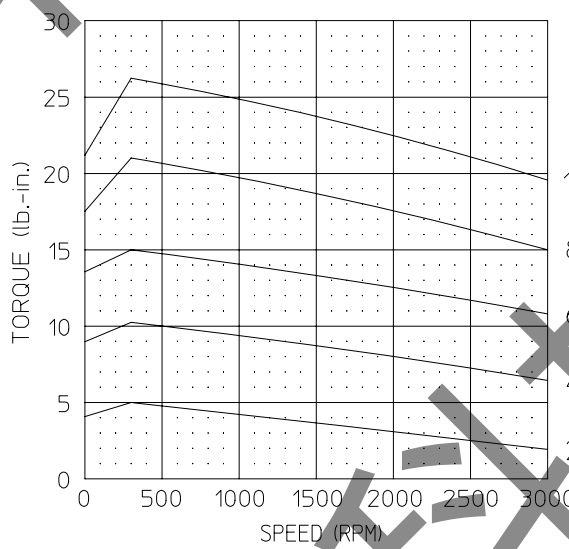
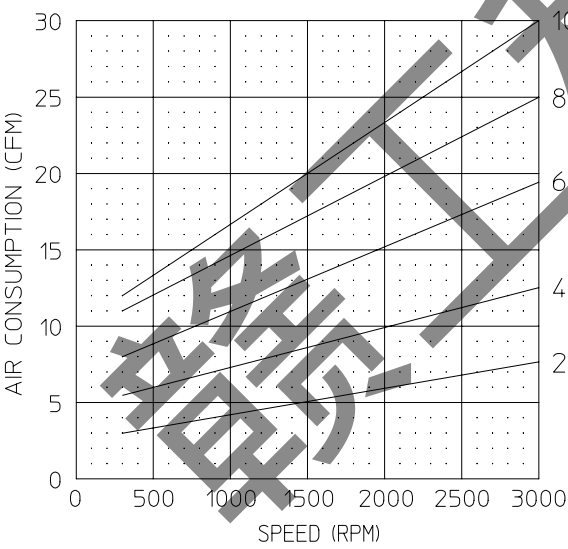

MUFFLER ASSEMBLY SHIPPED UNATTACHED

